

**Methodology Article**

# Weld Tracking System for the Boiler's Membrane Wall Overlaying

**Imran Dawy, Tian Songya**

Faculty of Mechanical and Electrical Engineering, Hohai University, Changzhou, China

**Email address:**

imran333@qq.com (I. Dawy), tiansongya@126.com (Tian Songya)

**To cite this article:**Imran Dawy, Tian Songya. Weld tracking System for the Boiler's Membrane Wall Overlaying. *International Journal of Intelligent Information Systems*. Vol. 8, No. 1, 2019, pp. 1-5. doi: 10.11648/j.ijjis.20190801.11**Received:** January 15, 2019; **Accepted:** February 22, 2019; **Published:** March 6, 2019

---

**Abstract:** The membrane wall is one of the important parts in the boiler industry. It is a pipe-plate structure; The length of the pipe is much longer than it is outer diameter. The chemical reactions of the liquid inside the boilers lead to corrosion problem of the membrane wall. In order to protect the membrane wall from corrosion, overlaying weld should be applied. The structure of the membrane wall has low stiffness and can be easily deformed. Therefore, for automatic overlaying weld, a sensor is required to ensure the distance between the welding torch and the membrane wall. In this paper, a tracking contact sensor based on the potentiometer is introduced for membrane wall pipes. The proposed sensor is composed of three displacement detectors. The left and right ones detect the position deviation between the welding torch and the pipe in the left and right sides, respectively. The middle one detects the deviation between the torch and the pipe in the middle point. Hence, based on the negative feedback from the sensor, the torch position will be adjusted. Finally, the real-time tracking of the torch to the membrane wall is realized and the problem of welding position deviation due to the membrane wall deformation is determined.

**Keywords:** Sensor, Surfacing, Weld Seam Tracking, Membrane Wall of Boiler

---

## 1. Introduction

The sensor technology offers great solution in our daily life activities, starting from big aero planes to any simple automatic process that requires sensors. Sensors are used in monitoring and data collection for different control purposes. Depending on the sensor applications, different kinds of sensors were made. In weld tracking control systems, sensors are utilized to extract the information of the welding process, such as arc length, seam center of fillet, etc. According to the geometrical profile of the weld pieces and the demands of high precision and productivity, numerous designs of sensors have been made. Regarding to the both seam detection and the method which has been used, Gupta classified the welding sensors into external and internal sensors; He divided the external sensors into contact and noncontact sensors [1]. Cederberg divided the welding sensors to four groups: wire touch sensing, through-arc sensing, vision guided line scan and vision guided circular systems [2]. The acquired features from the sensors are used to set a tracking mechanism for the

weld torch. For years, different kinds of sensors for seam detection and weld pool sensing were developed. P. Sicard used laser scanner connected with the computer for automatic joint guidance [3]. K.-y. Bae developed a visual sensing for automatic gas metal arc welding (GMAW) [4]. Kang-yul Bae discussed an electromagnetic sensor consisting of one exciter and three separated (triple) detectors to track the welding path [5]. J. W. Kim designed a dual - electromagnetic sensor for seam tracking [6]. Huang, W developed a laser-based vision system for non-destructive weld quality inspection [7]. J. Sun used a system consists of CCD camera with a line structure laser for seam detection in the robotic arc welding [8]. X. Li proposed a robust automatic welding seam identification to increase the precision of the welding position [9]. Fei Gao developed a contact sensor to increase the precision of the welding position and productivity in the hull welding [10].

In the cited work and others, it is seen that numerous parameters were considered in the tracking method selection, among them the geometrical profile of the weld pieces and productivity are main parameters in industrial welding which have influence in the tracking method realizability.

The potentiometer is an important invention in engineering field and it has been used as position measurement for more than a century, and recent technical advances have developed potentiometer characteristic and capabilities. Nowadays, potentiometers are widely applied for sensor applications. E. B. Mathew designed a robotic arm controlled by using potentiometer mounted at the joints of the human arm [11]. B. Luce used the potentiometer for the multi-fan hovering system [12]. J.-M. Hollerbach developed a potentiometer for controlling the robot hand [13]. Byoung -oh kam designed a two wheeled welding mobile robot used the potentiometer to control the body velocity and position [14].

Boilers are heat-transfer devices, wherein water in the form of either liquid water or gaseous steam, are commonly employed as a medium for the transport of heat to some distant point of use [15]. The boiler has been developed by obtaining good furnace gas seal, reducing furnace air leakage and use micro-positive pressure combustion to create conditions that cancel the operation of the induced draft fan. In spite of all these developments, the boiler's membrane wall still experiences the corrosion problem. Corrosion is the active destruction of sound boiler metal by the pitting action of dissolved oxygen in the boiler water. In order to protect the boilers from corrosion, the surfacing process was discussed to cover the membrane wall of boiler with a corrosion protection layer. For quality welding and productivity, the surfacing process is turned to be robotized and the welding track needs to be known. The membrane wall is constructed from pipes and steel plates jointed together, the structure of the membrane wall has low stiffness and tends to be deformed, so for the weld tracking over the membrane wall pipes, a geometrical contact sensor based on the linear potentiometer is proposed in this article. The design and principle of the sensor will be discussed in the following sections.

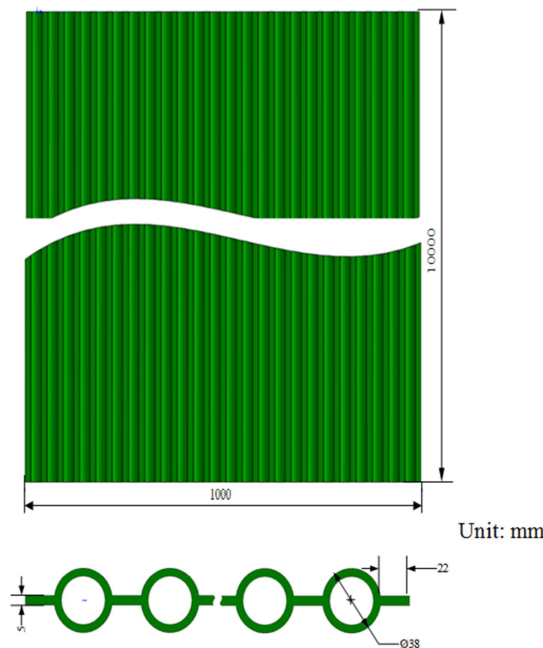

Figure 1. The boiler membrane wall structure.

## 2. The Structure of the Membrane Wall

The structure of the boiler's membrane wall is shown in figure 1. The pipes and the steel plates are joined together by welding. The pipes have diameter of 38mm. The steel plates have thickness 5mm and width length 22mm between any two pipes. The material is Q235B. The overall structure has length 10m and general width between 1-2m. The length of the membrane wall is obviously larger than the width, according to that, the stiffness along the pipes of the membrane wall will reduce. So, the pipes deformation happens during the manufacturing and Installation processes. Therefore, sensor is needed to acquire the exact weld position over the pipes.

## 3. The Structure of the Sensor

The membrane wall detecting position sensor consists of: the main body, the cover, the spring and three displacement detectors installed inside the body, figure 2. The cover is used to fix the sliding rheostat. The position and the assembly relation of the three displacement detectors inside the sensor body are depicted in figure 3.

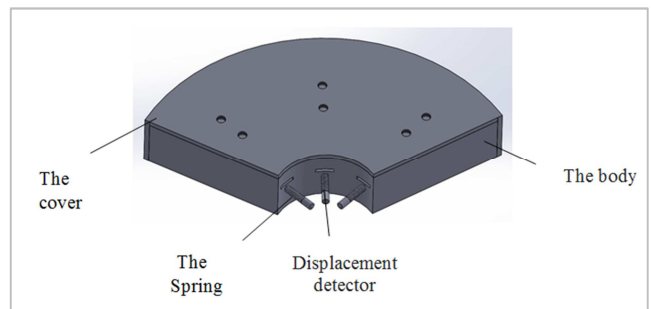

Figure 2. Over all structure diagram of the membrane wall sensor.

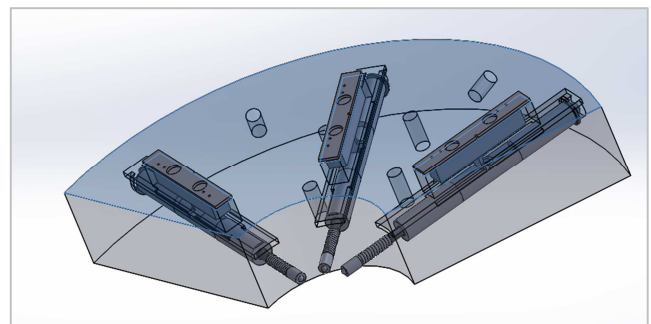

Figure 3. Assembly position of the three-displacement detector inside the sensor body.

### 3.1. The Body of the Sensor

The body of the sensor is designed with accordance of the dimensions of the membrane wall pipes, the design of the body is shown in figure 4. Three rectangular slots are made to place the sliding rheostat. The slots lock the rheostat and only let the slider to move in linear axis according to the membrane wall pipes deformation.

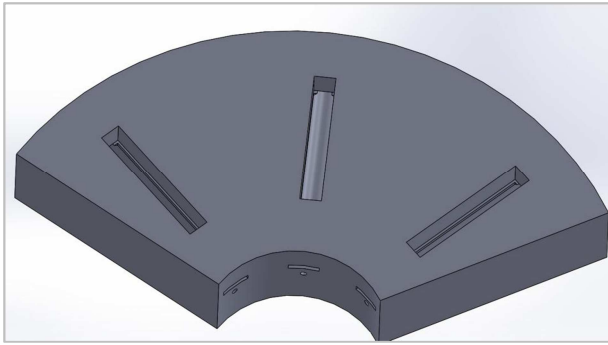

Figure 4. The body of the sensor.

### 3.2. The Displacement Detector

The structure of the displacement detectors inside the slots of the sensor body is shown in figure 5. The structure composes of shaft, opening retaining ring, rheostat, the slider, linear bearing, spring and contact.

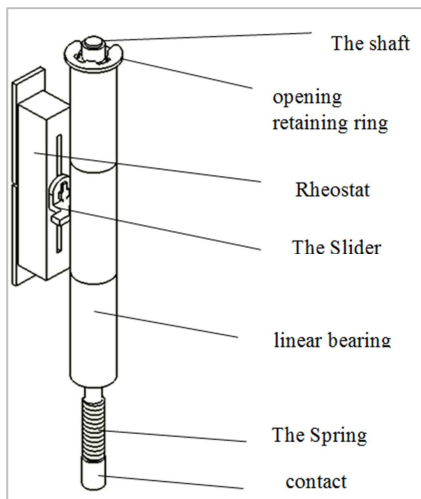

Figure 5. The displacement detector.

The spring acts as pre-pressing action. The contact is fixed at the shaft head to prevent the spring from slipping out and to be touched the membrane wall surface. The linear bearing is used to constrain the circumferential movement of the shaft. So, the shaft can only move along the axial direction. The moving part of the rheostat is fixed on the shaft through the slider. So, when the shaft moves forward and backward, the slider will move and the resistance value will be changed.

### 3.3. Working Principle

The equivalent circuit of the sensor is presented in figure 6. When the sensor receives the offset of the pipe, the tracking mechanism regulates the distance between the welding torch and the pipe. So, the welding gun keeps track the pipe with correct welding position. From the schematic diagram of the sensor figure 7. The relation between the (x, y) values (a, b) of the pipe's center after deformation and the displacements ( $\Delta l_1, \Delta l_2, \Delta l_3$ ) of the detectors (1, 2 and 3) can be developed by making quantitative analysis.

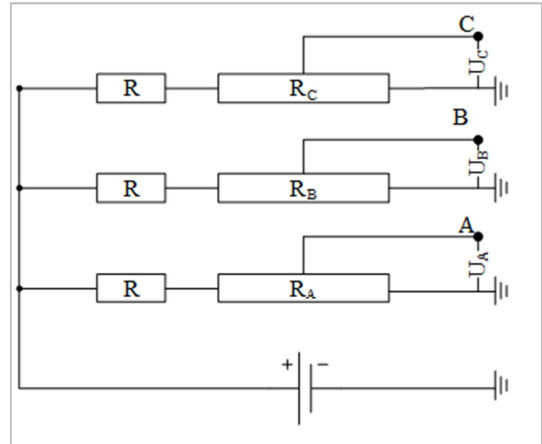

Figure 6. Sensor equivalent circuit.

The sliding end is connected to the sensor detector, the detector contact is contiguous to the pipe surface through the spring. When the detector of the sensor moves over the pipes surface, the output voltage  $U_A, U_B$  and  $U_C$  between the sliding end and the end of the potentiometers will change. The output voltage will compare with the offset voltage. Then, the voltage difference will be obtained accordingly. The sign and magnitude of the voltage difference are similar to the direction and value of the shaft's movement, and it is also the direction and value of the pipe's deformation. By the result of the voltage differences, the data collection is completed, and the adjustment values and directions of the welding torch can be obtained by further data processing.

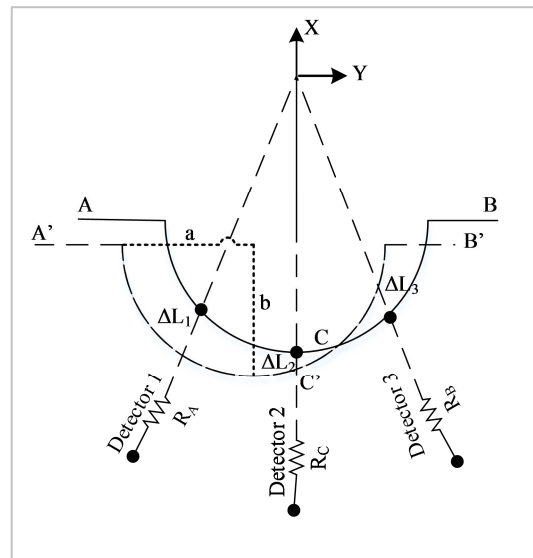

Figure 7. Sensor schematic diagram.

For the initial points of the sensor, the center of the pipes is set to be the origin of the coordinate system, the X axis is parallel to the membrane wall, and the Y axis is perpendicular to the membrane wall. Therefore, based on the dimensions of the pipe, the sensor detectors will be contacted the pipe at initial coordinates (A, C, B): (-13.433, -13.433), (0, -19), (13.433, -13.433). Figure 8. Shows the initial contact position of the detectors.

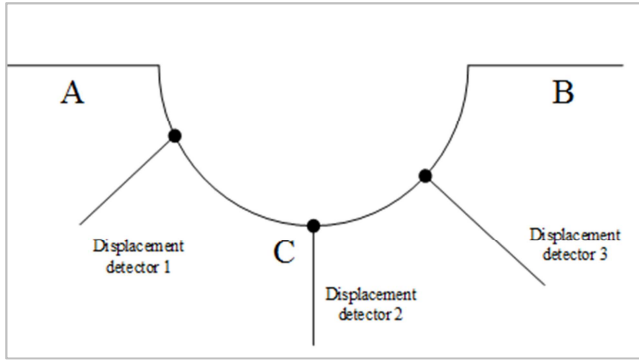

Figure 8. The initial contact position of the detectors.

### 4. The Deviation of the Membrane Wall Pipes

When the deformation occurred, the pipes parameters will accordingly change. As it can be seen in figure 8 and figure 9, the pipe position might be changed from  $AB$  to  $A'B'$  and the displacements of the detectors from their initial points will be  $\Delta l_1, \Delta l_2, \Delta l_3$  relatively. The displacements have positive and negative values, depends on the detectors moving direction,

with or against the axial. The coordinates of the corresponding three contacts points after deformation ( $A', C', B'$ ) are:  
 $(-13.433 + \Delta l_1 \cos 45^\circ, -13.433 + \Delta l_1 \sin 45^\circ)$ ;  $(0, -19 + \Delta l_2)$ ;  $(13.433 - \Delta l_3 \cos 45^\circ, -13.433 + \Delta l_3 \sin 45^\circ)$ .

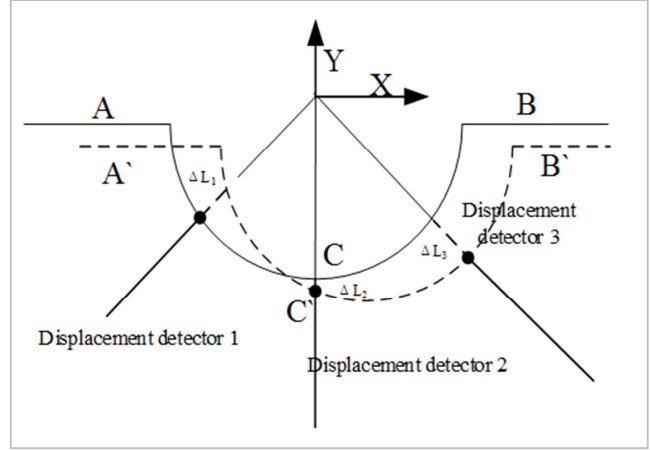

Figure 9. The membrane wall (x, y) deformation.

Therefore, the following equations can be developed:

$$\left(-19\frac{\sqrt{2}}{2} + \Delta l_1 \cos 45^\circ - a\right)^2 + \left(-19\frac{\sqrt{2}}{2} + \Delta l_1 \sin 45^\circ - b\right)^2 = 19^2 \tag{1}$$

$$a^2 + (-19 + \Delta l_2 - b)^2 = 19^2 \tag{2}$$

$$\left(19\frac{\sqrt{2}}{2} - \Delta l_3 \cos 45^\circ - a\right)^2 + \left(-19\frac{\sqrt{2}}{2} + \Delta l_3 \sin 45^\circ - b\right)^2 = 19^2 \tag{3}$$

The three equations are the (x, y) displacement of the detectors one, two and three. The variables  $a$  and  $b$  are the  $X, Y$  values of the pipe center after the deformation. By solving the above equations, the following results are obtained:

$$\Delta l_3^2 - \Delta l_1^2 + 38(\Delta l_1 - \Delta l_3) + \sqrt{2}(\Delta l_3 + \Delta l_1)a - 38\sqrt{2}a + \sqrt{2}(\Delta l_1 - \Delta l_3)b = 0 \tag{4}$$

$$\Delta l_3^2 - \Delta l_2^2 + 19\sqrt{2}(b - a) + 38(\Delta l_2 - \Delta l_3) - 38b + 2b\Delta l_2 - \sqrt{2}b\Delta l_3 + \sqrt{2}a\Delta l_3 = 0 \tag{5}$$

From equations (4, 5) the parameters ( $a_1, a_2, b_1, b_2, c_1, c_2$ ) have assigned as following :

$$c_1 = \Delta l_1^2 - \Delta l_3^2 - 38(\Delta l_1 - \Delta l_3) \tag{6}$$

$$c_2 = \Delta l_3^2 - \Delta l_2^2 - 38(\Delta l_3 - \Delta l_2) \tag{7}$$

$$a_1 = \sqrt{2}[38 - (\Delta l_3 + \Delta l_1)] \tag{8}$$

$$b_1 = \sqrt{2}(\Delta l_3 - \Delta l_1) \tag{9}$$

$$a_2 = \sqrt{2}(\Delta l_3 - 19) \tag{10}$$

$$b_2 = (19\sqrt{2} - 38 + 2\Delta l_2 - \sqrt{2}\Delta l_3) \tag{11}$$

Hence, the  $X, Y$  values (a, b) of the new pipe position can be obtained by using the equations (12, 13).

$$b = \frac{c_2 a_1 - c_1 a_2}{a_2 b_1 - a_1 b_2} \tag{12}$$

$$a = \frac{c_2 b_1 - c_1 b_2}{a_1 b_2 - a_2 b_1} \tag{13}$$

### 4. Conclusion

To fit the demands of the welding accuracy with full appropriate conditions that required in today's applications, automatic welding machine and welding robotic was introduced. Boilers are common devices used for liquid heating, and after a period life time, a chemical reaction happens and causes corrosion to the boiler's membrane wall. As a solution for the problem, surfacing process is necessary to create a corrosion protection layer. For the automatic overlaying process, the boiler's membrane wall pipes don't have same parameters and need to be tracked. A contact sensor based on the principle of the potentiometer was developed for the boiler's membrane wall. The sensor design and working principle were discussed in this article. The sensor consists of three detectors touching the pipe surface in one end and connected to the potentiometers from the second end. By using the detectors data ( $\Delta l_1, \Delta l_2, \Delta l_3$ ), the (x, y) values (a, b) of the new pipe center after deformation was calculated. The sensor is a new design of weld tracking system over the pipes

of the membrane wall and it can be used for any tracking system which has the same geometrical features. For further study, based on the sensor collected data, different control methods can be studied for obtaining the best response from the system.

---

## References

- [1] Gupta, A. K.; Arora, S. K. *Industrial Automation and Robotics*. Laxmi Publications, New Delhi, 2007.
- [2] Cederberg, P. *On Sensor-Controlled Robotized One-off Manufacturing*, doctorate, Lund University, Sweden, 2004.
- [3] P. Sicard and M. D. Levine, "Joint recognition and tracking for robotic arc welding," in *IEEE Transactions on Systems, Man, and Cybernetics*, vol. 19, no. 4, pp. 714-728, Jul/Aug 1989.
- [4] K.-Y. Bae, T.-H. Lee, K.-C. Ahn, An optical sensing system for seam tracking and weld pool control in gas metal arc welding of steel pipe, In *Journal of Materials Processing Technology*, Volume 120, Issues 1–3, 2002, Pages 458-465, ISSN 0924-0136, [https://doi.org/10.1016/S0924-0136\(01\)01216-X](https://doi.org/10.1016/S0924-0136(01)01216-X).
- [5] Kang-Yul Bae, Jin-Hyun Park, A study on development of inductive sensor for automatic weld seam tracking, In *Journal of Materials Processing Technology*, Volume 176, Issues 1–3, 2006, Pages 111-116, ISSN 0924-0136, <https://doi.org/10.1016/j.jmatprotec.2006.02.020>.
- [6] J. W. Kim, J. H. Shin, A study of a dual-electromagnetic sensor system for weld seam tracking of I-butt joints, *Proc. Inst. Mech. Eng. Part B: J. Eng. Manuf.* 217(2003) 1305–1313.
- [7] Huang, W.; Kovacevic, R. A Laser-Based Vision System for Weld Quality Inspection. *Sensors* 2011, *11*, 506-521.
- [8] J. Sun, G. Cao, S. Huang, K. Chen and J. Yang, "Welding seam detection and feature point extraction for robotic arc welding using laser-vision," *2016 13th International Conference on Ubiquitous Robots and Ambient Intelligence (URAI)*, Xi'an, 2016, pp. 644-647.
- [9] X. Li, X. Li, S. S. Ge, M. O. Khyam and C. Luo, "Automatic Welding Seam Tracking and Identification," in *IEEE Transactions on Industrial Electronics*, vol. 64, no. 9, pp. 7261-7271, Sept. 2017.
- [10] Fei Gao, Qinglan Chen and Lanzhong Guo, "Study on arc welding robot weld seam touch sensing location method for structural parts of hull," *2015 International Conference on Control, Automation and Information Sciences (ICCAIS)*, Changshu, 2015, pp. 42-46.
- [11] E. B. Mathew, D. Khanduja, B. Sapra and B. Bhushan, "Robotic arm control through human arm movement detection using potentiometers," *2015 International Conference on Recent Developments in Control, Automation and Power Engineering (RDCAPE)*, Noida, 2015, pp. 298-303.
- [12] B. Luce, K. Rahnamai, "Controller design for a multi-fan hovering system," in *Proceedings of Electrical Insulation Conference and Electrical Manufacturing & Coil Winding Conference*, pp.311-317, Oct.2001.
- [13] J.-M. Hollerbach, D.-M. Lokhorst, "Closed-loop kinematic calibration of the RSI 6-DOF hand controller," *IEEE Transactions on Robotics and Automation*, vol. 11, no. 3, pp.352-359, June 1995.
- [14] Byoung-Oh Kam, Yang-Bae Jeon and Sang-Bong Kim, "Motion control of two-wheeled welding mobile robot with seam tracking sensor," *ISIE 2001. 2001 IEEE International*.
- [15] Taler, J., Duda, P., Węglowski, B., Zima, W., Grądziel, S., Sobota, T. and Taler, D., 2009. Identification of local heat flux to membrane water-walls in steam boilers. *Fuel*, 88(2), pp.305-311.